



Aerosol & Filling Machine Bag on Valve Specialists



FILL PUMP RACKS ASSEMBLY & ACCESSORIES

MBC-AEROSOL.COM

OVERVIEW

In an ever-expanding industry, it can be tough to stay on top of the latest technology and processes to keep your brand ahead of the game. New lines are costly, and existing machinery falls short in production or sanitary capabilities. MBC Aerosol has the solution.

Why not take advantage of a **Fill Pump Rack** and all it can offer?



Cost-Reduction

Our metering cylinders include built-in, air-saving technology, so you only use the energy you need, reducing your carbon footprint. No need for an entirely new machine – this simple assembly addition can be added to your existing lines, creating all new potential for your product line. The unique liquid-seal design prevents leaks, eliminating the need for adjustments and repairs during production.



Accuracy

This assembly uses a positive displacement method, allowing for an adjustable amount of your product without waste. The O-ring seal delivers exact, repeatable dosing and the stroke-lock-handle helps maintain overall precision. Cross-contamination is eliminated by the ability to offer each client the potential for their own dedicated fill parts. Several standard sizes from 10ml-500ml are available as well as different injection-pressure-ratio designs, allowing for a completely customizable system.

Convenience

Easy cleaning along with quick disassembly and reassembly allows for simple changeovers – making it ideal to share across several lines.

Includes a quick-disconnect, communication control module to assist in rapid cleaning or changeover.

Reliability

Over a decade of data shows our metering cylinder system can properly manage an array of aerosol products including saline, food oils, chemicals, lotions, cosmetics and paints.



BREAKDOWN

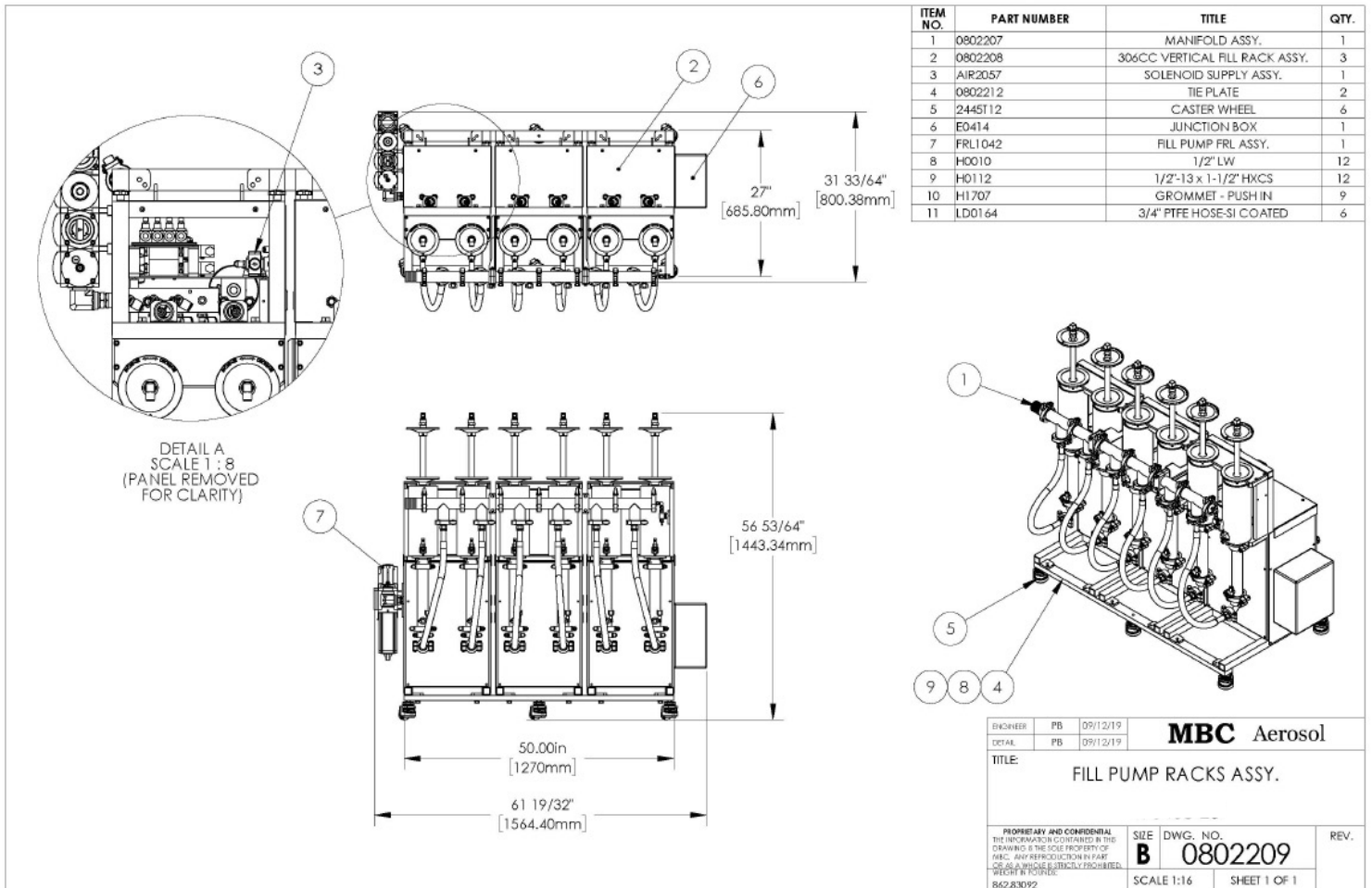

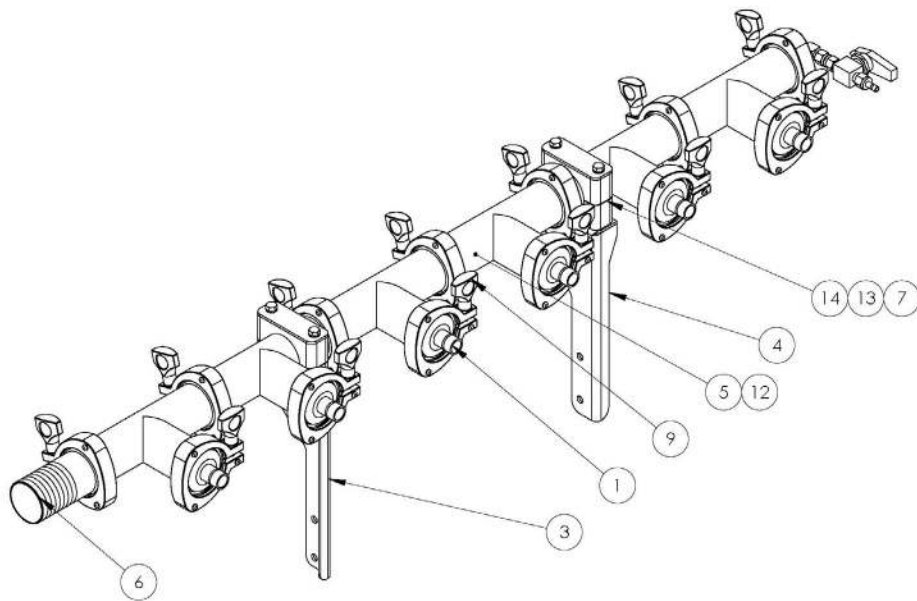
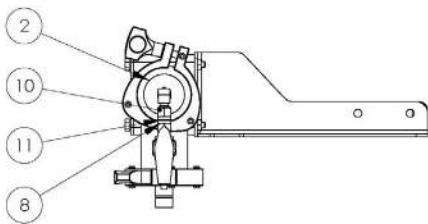

ITEM NO.	PART NUMBER	TITLE	QTY.
1	0802213	SANITARY FITTING-3/4 TUBE STUB TO 1" SANITARY	6
2	0802214	SANITARY FITTING-1/4 TUBE STUB TO 2" SANITARY	1
3	0802215	MANIFOLD SUPPORT	1
4	0802216	MANIFOLD SUPPORT	1
5	50485K143	FITTING,TEE	6
6	50485K775	2" SANITARY HOSE CONNECTOR (31 6SS)	1
7	H0007	1/4" LW	4
8	H0195	1/4" COMP 2-WAY BALL VALVE	1
9	H0376	2" SANITARY TRI-CLAMP	13
10	H0403	1/4" COMP UNION ELBOW	1
11	H0404	1/4" PORT CONNECTOR	2
12	H1509	2" GASKET PTFE	13
13	H2267	1/4-20 x 3 1/4" HXCS X 0.75-N	4
14	H3155	CLAMP-2"	2

ENGINEER	PB	09/11/19	MBC Aerosol
DETAIL	PB	09/11/19	
TITLE:			
MANIFOLD ASSY. INLINE FILLER			
<small>PROPRIETARY AND CONFIDENTIAL THE INFORMATION CONTAINED IN THIS DRAWING IS THE SOLE PROPERTY OF MBC. ANY REPRODUCTION IN PART OR AS A WHOLE IS STRICTLY PROHIBITED.</small>		SIZE DWG. NO. B 0802207	REV.
WEIGHT REQUIRED: 24.95627		SCALE 1:4	SHEET 1 OF 1

DETAILS



Easy Tri-clamp Breakdown for Cleaning or Change-over



Flow Throttle Valves



Volume Adjustment with Lock Handle



Precise Speed Control

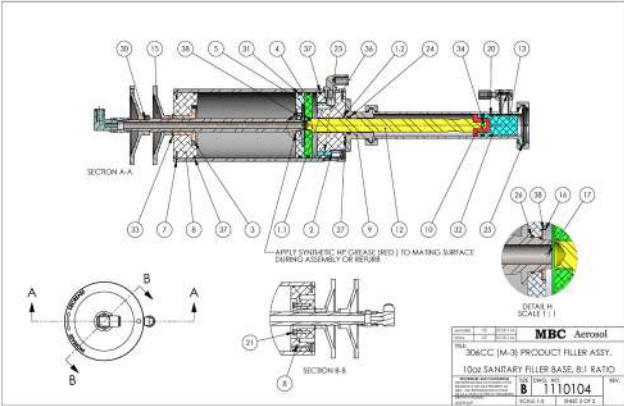

Metering Cylinder Breakdown

SPECIAL FEATURES



FRL System to Project the Pneumatic System



Easy View Water and Oil Level

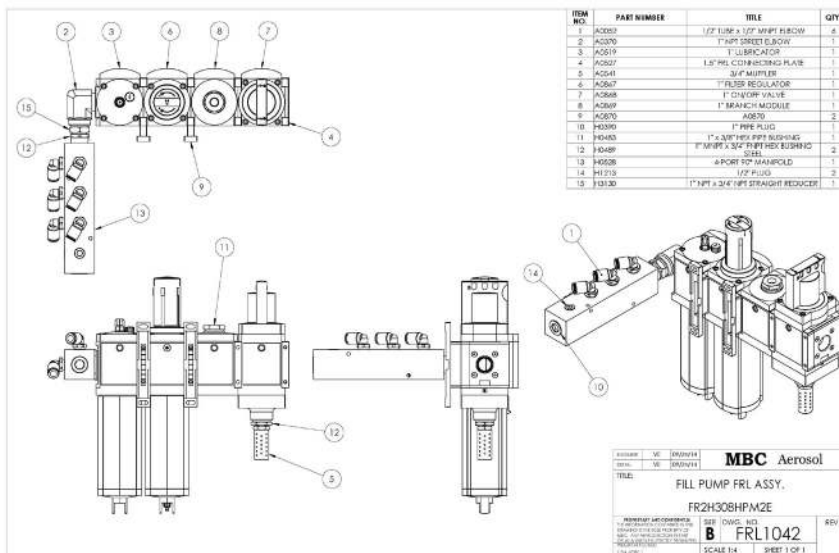

FRL System Assembly



Pressure Switch to Monitor Incoming Air Supply for PLC Control Versions

OPTIONAL ACCESSORIES



Sanitary Open Top Nozzle



BOV Filling Head

CONTACT INFORMATION

CORPORATE HEADQUARTERS

Mailing Address:
MBC Aerosol
PO Box 54
South Elgin, IL 60177

Shipping Address:
MBC Aerosol
445 Renner Drive
Elgin, IL 60123

Mon-Fri: 8:00am to 4:30pm CST
Sat/Sun: By appointment only

Phone: 1-847-214-8843
Fax: 1-888-244-8597

Sales Department:
Direct: 1-224-276-2520
Email: sales@mbc-aerosol.com

Parts Department:
Direct: 1-224-276-2527
Email: parts@mbc-aerosol.com

Service Department:
Direct: 1-224-276-2527
Email: service@mbc-aerosol.com

Shipping Department:
Direct: 1-224-276-2531
Email: shipping@mbc-aerosol.com

Engineering Department:
Email: engineering@mbc-aerosol.com

Accounting Department:



PARTNERS

CENTRAL & SOUTH AMERICA

Equipo y Sistema para Envase, Empaque, Embalaje
Heraclito 327

Col. Polanco

11560 México, D.F.

Tel: 55-5545 4972 | Fax: 55-5545 2127

E-mail: sales-sa@mbc-aerosol.com | Website: www.
grupomarlaw.com

EUROPE

Budé Innovative Solutions bv

Karveelweg 3

6222 NJ Maastricht

The Netherlands

Tel: +31 43 – 363 57 00 | Mobile: +31 6-21 53 48 49

E-mail: sales-eu@mbc-aerosol.com | Website: www.
bude.com

AUSTRALIA

HBM Plastics & Packaging Technologies Pty Ltd

Street: 46/5 Inglewood Place, Baulkham Hills NSW

2153 Australia

Postal:

P.O. Box 6167 Baulkham Hills BC, NSW 2153 Aus-

tralia

Website: www.hbm.com.au | Phone: +61 2 8814 3100

(main)

Vijay Kumar

Project/Sales Engineer

Phone: +61 2 8814 3109 (direct)

Email: sales-au@mbc-aerosol.com

Mobile: +61 419 011 754

ASIA & INDIA

TST Technical Solutions

51/303 Ivy River Condominium

Floor 18 Ratburana Rd

Bangpakok, Ratburana Bangkok 10140 Thailand

David Cull

Office phone: +66 (0) 2-874-1112

Fax: +66 (0) 2-870-9632

Mobile: +66 89-202-2484

email: sales-as@mbc-aerosol.com

RUSSIA

Vergos Ltd.

Krylenko St. 43-2-174

St. Petersburg, 193232

Russian Federation

Vera Galakhova

Office phone: +7 985-960-0191

Fax: +7 911-013-3608

Mobile: +7 (911) 013-36-08

email: sales-eu@mbc-aerosol.com

